

GTR – torsionally rigid coupling: introduction



- Made in steel fully turned with standard treatment of phosphating.
- Disc pack in stainless steel.
- High torsional rigidity.
- Maintenance and wear free.
- Version with double disc pack and spacer made to length.
- High torque possible.

ON REQUEST

- Use in applications with high operation temperatures (> 150 °C) possible.
- Specific treatments or version in full stainless steel possible.
- Customized versions for specific needs.
- Connection to ComInTec TORQUE LIMITERS range possible.

Designed to suit applications where high reliability, precision and an optimum weight/power ratio is required; ideally suited for applications with high speeds and power, also offering low overhung loads when using spacer version.

This coupling is composed of three main items: the two fully turned hubs, made in steel UNI EN10083/98 and the disc pack, in stainless steel AISI 304 C with connection screws in steel class 10.9. In the “double” version, GTR/D, there is also a spacer made to length, also built in steel UNI EN10083/98, fixed between the hubs and the two disc packs.

All the components of GTR couplings, except the spacer, are made and balanced into class DIN ISO 1940-1:2003 Q 6.3, before the machining of the keyway.

In accordance to the specific need of the application, it is possible to make static or dynamic balancing on each separate component or on the coupling, fully assembled to customer requirements.

DESCRIPTION OF DISCS

The fundamental elements of this torsionally rigid coupling are the disc packs, built from a series of stainless steel discs type AISI 304-C, connected by steel bushes. This disc pack is connected in an alternate way to the hub flange or the eventual spacer, by using screws in steel class 10.9 and the relevant self-locking nuts.

With reference to the configuration, the disc packs can be:

- Unique discs with continuous ring (coupling sizes 1-7)
- Disc sections (coupling sizes 8-12)

Continuous ring disc pack
(sizes 1-7)

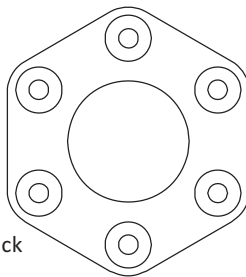

Sectional disc pack
(sizes 8-12)

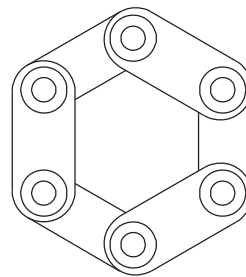

Assembly example with internal and external locking bushes

GTR – torsionally rigid coupling: introduction

MANUFACTURING

Version with spacer supplied, made to length, according to the application needs.

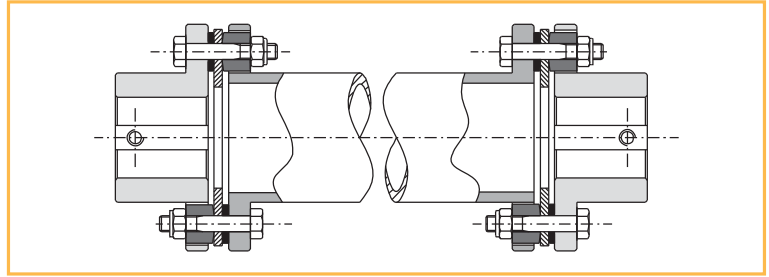

Manufacturing with internal hubs in order to reduce the axial dimensions.

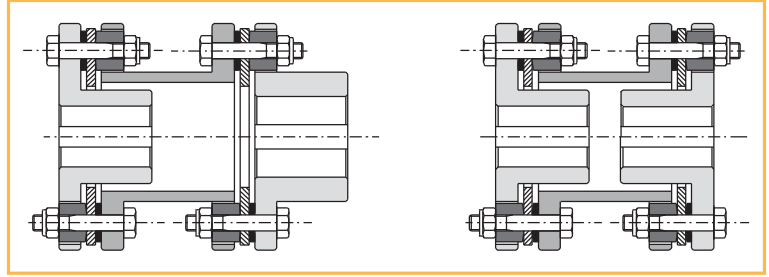

Manufacturing in addition to the /SG torque limiters range, with simple and/or double disc pack.

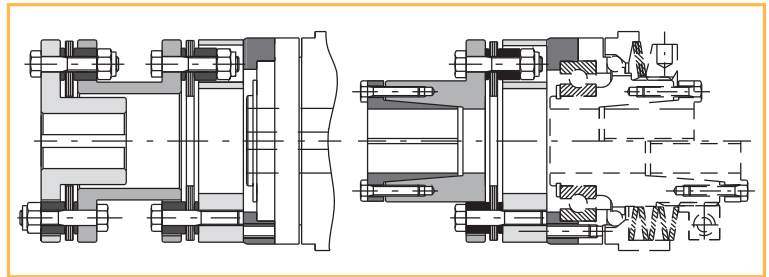

Solution with adaptors both in simple and double version, for easy substitution of disc packs without moving the hubs (in accordance with directive API610).

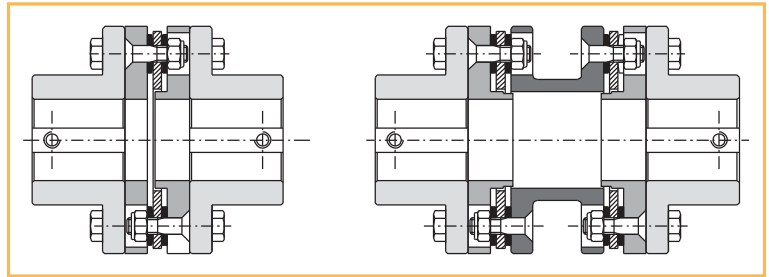

Solution for vertical mounting, where the spacer has to be supported to avoid the weight pre-loading the disc pack.

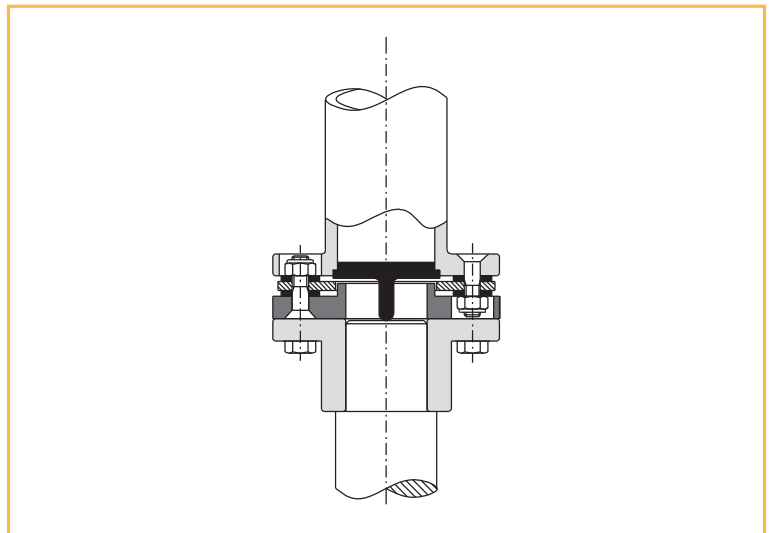

GTR – torsionally rigid coupling: technical data

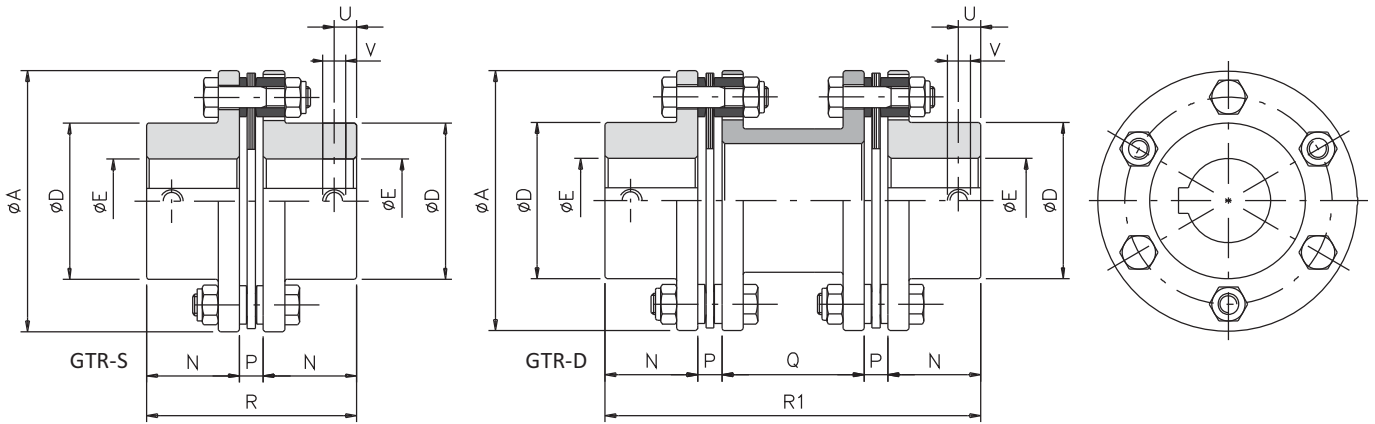

DIMENSIONS

Size	GTR-S code	GTR-D code	A	D	E H7 max	E4 H7 max	N	P	Q Std *	R	R1	U	V
0	200965000000	200819000000	78	45	32	25	29	7,5	50	65,5	123	10	M5
1	200825000000	200829000000	80	45	32	25	36	8	50	80	138	10	M5
2	200835000000	200839000000	92	53	38	30	42	8	50	92	150	10	M5
3	200845000000	200849000000	112	64	45	35	46	10	59	102	171	15	M8
4	200855000000	200859000000	136	76	52	45	56	12	75	124	211	15	M8
5	200865000000	200869000000	162	92	65	55	66	13	95	145	253	20	M8
6	200875000000	200879000000	182	112	80	70	80	14	102	174	290	20	M8
7	200885000000	200889000000	206	130	90	80	92	15	101	199	315	20	M10
8	200895000000	200899000000	226	135	95	80	100	22	136	222	380	20	M10
9	200925000000	200929000000	252	155	110	-	110	25	130	245	400	25	M12
10	200935000000	200939000000	296	170	120	-	120	28	144	268	440	25	M12
11	200945000000	200949000000	318	195	138	-	140	32	136	312	480	30	M16
12	200955000000	200959000000	320	200	140	-	150	32	156	332	520	30	M16

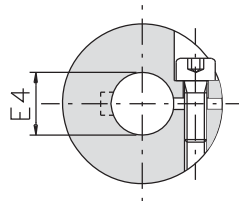

Clamp locking (on request)

TORQUE PERMISSIBLE WITH CLAMP LOCKING (GTR-S & GTR-D)

Size	Torque transmitted [Nm] relevant to the ϕ finished bore [mm]																													
	10	11	12	14	15	16	18	19	20	22	24	25	28	30	32	35	38	40	42	45	48	50	55	60	65	70	75	80		
0	18	19	19	20	20	21	22	22	22	23	24	25																		
1	18	19	19	20	20	21	22	22	22	23	24	25																		
2			41	42	43	44	45	45	46	47	49	49	51	53																
3							90	91	92	95	97	98	102	104	107	110														
4									95	97	99	101	104	106	108	111	115	117	119	123										
5												260	267	272	276	284	291	296	301	308	316	321	333							
6																	494	501	508	519	530	537	555	573	591	609				
7																			539	549	560	567	585	603	621	639	657	676		
8																				1097	1117	1131	1166	1201	1236	1271	1306	1342		

GTR-S TECHNICAL CHARACTERISTICS

Size	Torque [Nm]		Weight [Kg]	Inertia [Kgm ²]	Max speed [Rpm]	Axial load [Kg]	Tightening torque disc pack screws [Nm]	Misalignment			Rigidity [Nm/rad·10 ³]
	Nom	Max						angular α [°]	axial X [mm]	radial K [mm]	
0	60	120	1,6	0,00058	27500	10	12	1°	1,40	-	80
1	100	200	1,3	0,00067	25000	14	12	0° 45'	0,80	-	117
2	150	300	2,4	0,00193	22000	19	13	0° 45'	0,95	-	156
3	300	600	3,9	0,00386	20000	26	22	0° 45'	1,25	-	415
4	700	1400	6,3	0,00869	16000	34	39	0° 45'	1,45	-	970
5	1100	2200	10,4	0,01009	14000	53	85	0° 45'	1,65	-	1846
6	1700	3400	15,6	0,03648	12000	70	95	0° 45'	2,00	-	2242
7	2600	5200	24,8	0,07735	10000	79	127	0° 45'	2,25	-	3511
8	4000	8000	33,0	0,13403	8000	104	260	0° 45'	2,45	-	8991
9	7000	14000	42,0	0,25445	7500	115	480	0° 45'	2,55	-	11941
10	9000	18000	67,0	0,45019	6000	138	760	0° 45'	2,65	-	14154
11	12000	24000	94,0	0,71654	5500	279	780	0° 45'	2,95	-	15521
12	15000	30000	114,0	1,06933	5500	358	800	0° 45'	3,05	-	16409

GTR-D TECHNICAL CHARACTERISTICS

Size	Torque [Nm]		Weight [Kg]	Inertia [Kgm ²]	Max speed [Rpm]	Axial load [Kg]	Tightening torque disc pack screws [Nm]	Misalignments			Rigidity R _t [Nm/rad·10 ³]
	Nom	Max						angular α [°]	axial X [mm]	radial K [mm]	
0	60	120	1,7	0,00083	25000	12	12	1° 30'	1,40	0,70	42
1	100	200	1,8	0,00092	25000	14	13	1° 30'	1,60	0,79	51
2	150	300	3,5	0,00286	22000	19	13	1° 30'	1,90	0,79	71
3	300	600	5,8	0,00740	20000	26	22	1° 30'	2,50	0,95	184
4	700	1400	9,4	0,01660	16000	34	39	1° 30'	2,90	1,18	422
5	1100	2200	15,2	0,02850	14000	53	85	1° 30'	3,30	1,45	803
6	1700	3400	23	0,06358	12000	70	95	1° 30'	4,00	1,56	1019
7	2600	5200	34	0,12816	10000	79	127	1° 30'	4,50	1,57	1596
8	4000	8000	47	0,22927	8000	104	260	1° 30'	4,90	2,16	3996
9	7000	14000	61	0,44598	7500	115	480	1° 30'	5,10	2,16	5192
10	9000	18000	96	0,79995	6000	138	760	1° 30'	5,30	2,40	6024
11	12000	24000	132	1,22823	5500	279	780	1° 30'	5,90	2,40	6748
12	15000	30000	166	1,85186	5500	358	800	1° 30'	6,10	2,64	7293

NOTES

- ⊗ **Code:** the 7th, 8th, 9th digits of the code indicate the finished bore diameter of a half-hub in mm (000 = Pilot Bore).
- ⊗ **Code:** the 10th, 11th, 12th digits of the code indicate the finished bore diameter of the second half-hub in mm (000 = Pilot Bore).
- ⊗ **Q std (*):** different dimensions available on request.
- ⊗ **Technical characteristics:** the weights refer to the coupling with pilot bore; inertias refer to the coupling with maximum bore.